

# Lumisphere<sup>®</sup> Products Ltd

Delivering Decorative Lighting Festoons

[www.lumisphere.co.uk](http://www.lumisphere.co.uk)



*'Providing unique, innovative patented lighting systems for more than 30 years'*

Lumisphere® Products Ltd was formed in 1988 by Robert Ernest Myson specifically to provide the decorative lighting industry with a high quality, low maintenance, low voltage, festoon lighting system. The company used state of the art design, materials and technologies to combat the residual problems of traditional mains operated festoon systems, i.e. ingress of water, high operating and maintenance costs.

The company quickly established a worldwide reputation for quality and performance; Lumisphere® Products Ltd was the pioneer in low energy lighting. The energy efficient systems we designed remain in use after more than 25 years and have proven themselves in extreme conditions.

Rosedale Lighting has owned the company since 2008; the owners being in the lighting industry for over 30 years. Our head office is in North Yorkshire in the UK, covering the UK and worldwide, and we also have an agent in the USA.

The Lumisphere Team is on hand to assist you with your lighting project. Pre-installation and design advice is offered at no extra cost, ensuring trouble-free projects with longevity of service. We operate with a small but dedicated team who will work together to ensure a smooth service from your initial enquiry through to production and delivery of your bespoke lighting product.

We have amassed a vast technical knowledge base, with our products being used all over the world. Each project is individually manufactured to create variable systems for unique installations.

*'Customer service is unparalleled, with personal one-to-one contact throughout each project'*

**If you would like to submit a query, please don't hesitate to give us a call.**

We are developing new products all the time! Send us an email to [sales@lumisphere.co.uk](mailto:sales@lumisphere.co.uk) if you would like to keep in touch or Follow us on Facebook, Twitter and Instagram!

# CONTENTS

## Page

Large Harness Festoon Systems – General Information ..... 4 – 5



Large Harness Festoon Systems – X12 Static – Orbical & Eco ..... 6

Large Harness Festoon Systems – X12 Dimmable – Carnival..... 7

Large Harness Festoon Systems – Active **RGBW** (DMX) ..... 8 – 9

Large Harness Festoon Systems – X24 (Xenon) & Retrofit ..... 10

Large Harness Festoon Systems – Maintenance ..... 11

Small Harness Eco Festoon Systems ..... 12



Mini Light Systems ..... 13

Project Gallery ..... 14 – 15

Lanterns & Pendant Festoons..... 16 – 17

Transformers, Drivers, Dimming Packs & SSUs ..... 18 – 21

Installation Guide plus Fixings & Accessories ..... 22 – 25

More Gallery Images ..... 26 - 27

Contact Details..... 28

# LUMISPHERE® Large Harness Festoon Systems

Large Harness Orbical, Carnival, Active, Eco LED Systems & X24 Xenon



## ADVANTAGES

The Lumisphere® patented Low Voltage Festoon lighting system has been designed to provide a safe multipurpose energy saving system. It offers an attractive alternative to standard mains voltage festoon lighting which normally has inherently high maintenance and power costs.

## QUALITY & MAINTENANCE

- Pressure Watertight
- Conforms to IP68
- Used in Adverse Conditions & Humidity
- Complete Saturation in Saline Water
- High Quality
- Non-Corrosive
- Impact Resistant materials
- Festoons are UL2108 compliant
- Other than lamp replacement at long intervals, virtually no maintenance is required.

## GENERAL

The Lumisphere® low voltage festoon systems use unique design of cable and lampholders to full UL certification, achieving a clean modern festoon lighting system. The System comprises of specially designed 3mm 2 core cable which compresses into a patented lampholder, together with a tough polycarbonate globe, forming a weatherproof IP68 seal.

Lamp assemblies can be fitted at any spacings (centres) along the HOFR cable and, together with various LED or Xenon light sources, form a highly robust, energy efficient festoon lighting system. It can be used for many decorative applications such as Ships' lighting, Shopping Malls, Restaurants, Seaside Promenades to permanent or seasonal tree lighting. The System can also be supplied in component form for those clients wishing to self-assemble.

The System lends itself ideally to bespoke lighting applications where high illuminance, low energy and longevity are required.



## ENERGY

Energy costs are greatly reduced. For example:  
1 kilometre of festoon at 1metre spacing operating for 2000hrs use, expressed in units of electricity (kilowatt/hrs)  
240watt Mains system – 50,000 units of electricity.  
Lumisphere® Orbical 8 LED system – 1000 units of electricity.

## APPLICATIONS

- ✓ Coastal promenades & Piers
- ✓ Marine dressing lights
- ✓ Street & Building decorations
- ✓ Bar & Restaurant interior/exterior
- ✓ Retail ✓ Signs
- ✓ Trees ✓ Festive Occasions
- ✓ Hotels ✓ Swimming Pool areas
- ✓ Bridges
- ✓ Theatres ✓ Casinos
- ✓ Theme Parks
- ✓ Ornamental Gardens & Lakes
- ✓ Shopping Malls
- ✓ Weddings ✓ Parties
- ✓ Festivals ✓ Glamping
- ✓ Building Sites & Road Works ✓ Tunnels
- ✓ Emergency Lighting

## SAFETY

The Lumisphere® festoon system running at extra low voltage is ideally suited for permanent and temporary use in all environments particularly where accessible to the public. All materials used have high electrical and insulating qualities coupled with excellent flame retardant and flammability specifications. Lumisphere® systems may be used where mains voltage festoons would not comply with electrical safety regulation.

## LUMISPHERE® LED SYSTEMS

Lumisphere's comprehensive range of high quality LED plug in light modules are designed to meet all applications. Four types of LED are available' :

- Lumisphere® Orbical range of LEDs
- Lumisphere® Carnival range of LEDs
- Lumisphere® Eco range of LEDs
- Lumisphere® Active **RGBW** (DMX) LEDs
- Large Harness Lumisphere® system supplied in Black or White

Existing Lumisphere® X24 and X12 systems can be simply converted to LED by using the appropriate LED plug in light module and the fitting of Lumisphere® weatherproof LED power supplies in place of the existing Lumisphere® transformers, thus avoiding the need for costly festoon harness replacement.

## GLOBES

The Lumisphere® Globes are manufactured from UV stabilised polycarbonate. Two standard types are available, A type or G type, both are interchangeable with each other.



A Type



G Type

*'All our festoons are made bespoke to order'*

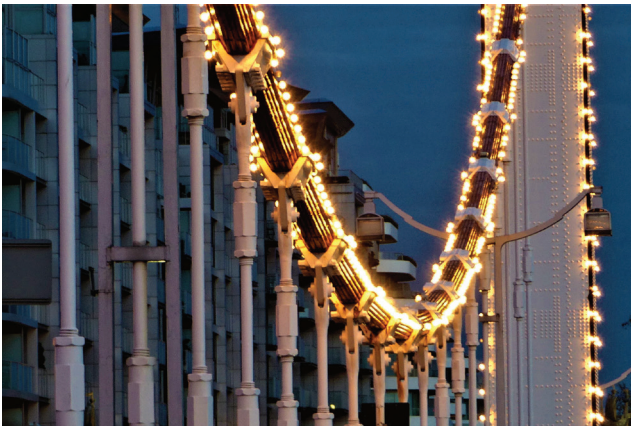

Chelsea Bridge X24 System



Orbical 24 LED festoon with Clear G Type globes

## ELECTRICAL, SAFETY & FLAMMABILITY SPECIFICATIONS

LAMP HOLDERS	Material Flammability	Nylon 66 Self Extinguished Grade UV stabilised Flammability rating to ASTN D 635 U.L. V2 UL Listing E170572 UL2108 compliant
GLOBE	Material Flammability Tensile Strength Impact Resistance	Polycarbonate UV stabilised Flame retardant grade U.L. V2 700KKG/CM2 80KG CM/CM
LAMPS	X24 LEDs	Lumisphere Special Xenon Gas Filled Lamps 24v; 5w, 8.5w and 10w LEDs Orbical, Active, Eco and Carnival ranges
CABLE	Material Flammability	Twin conductor stranded tinned copper 60/0.25 3.00mm2 Sheath – heat, oil and flame retardant rubber UV stabilised Conforms to BS4066 Part 1. EIC 332-1. UL. listed No. E168888(M) UL Listing E168888
TRANSFORMERS	Type WP Range Flammability	Lumisphere® Safety Isolating Transformer Comply with BS 3535 1.0 1990/IEC 742/EN 60-742 Clauses 7-26 IP55 Windings – Encapsulated in self-extinguishing grade urethane

# LUMISPHERE® Large Harness X12 Static

## Orbical LEDs



### Specifications

Supply	12V AC DC SELV
Light Source	Orbical 8/24/48
Env. Prot.	IP68
Conformity	BS EN 60958 CE UL Listed

The Lumisphere® Orbical LED range is a plug in LED light module which uses a number of SMD LEDs to create a 360° light source with similar light appearance to a traditional light bulb. The LED light unit is designed as a simple retro fit LED for any Lumisphere® existing X12 installation.

Colours:- Warm White, Cool White, Red, Blue, Amber, Green, Purple (Orbical 24 and 48 only)

#### COLOUR TEMP

Cool White 5500-6800K

Warm White 2800-3200K

#### LEDS IN THE ORBICAL RANGE

8 SMD Module rated at 1watt

24 SMD Module rated at 1.2watt

48 SMD Module rated at 2 watt

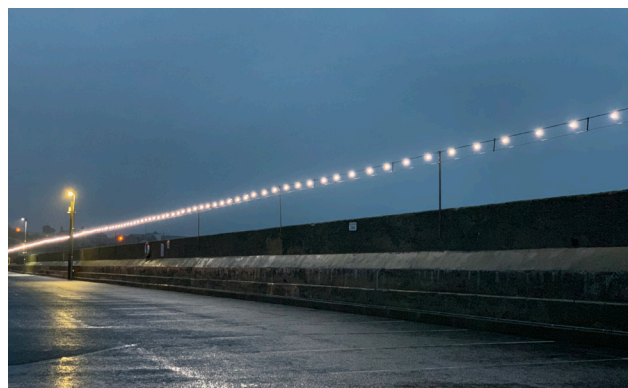

*Lumisphere Orbical 360/24 festoon in Cool White used for decorative harbour lighting*



*Orbical 24 LED range in colours. Clear G type polycarbonate globes.*

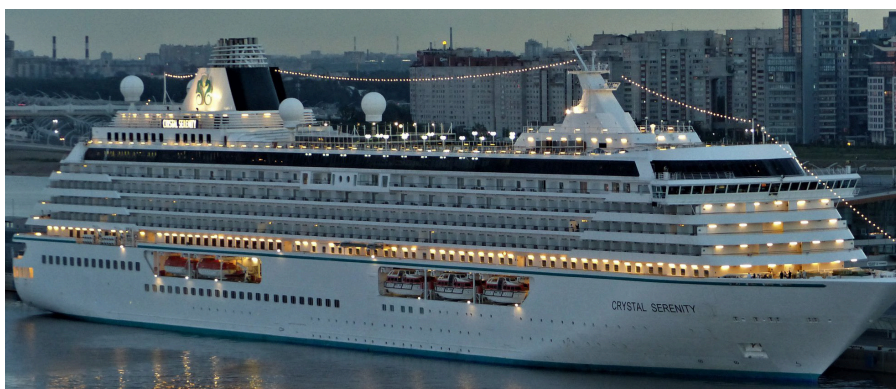

*Our IP68 Orbical LED Festoons are often used for marine dressing lights. They are attractive and highly robust, making them a perfect choice for use in adverse conditions*



*Large Harness Orbical 360/24 LED festoons in Warm White used for decorative lighting at Bicester Village*



*UV Stabilised WHITE lampholders and WHITE cable are available for all our Large Harness systems*

# LUMISPHERE® Large Harness X12 Dimmable

## Carnival LED (Dimmable)



### Specifications

Supply	12V AC/DC SELV
Dimmable	on AC/DC
Light Source	0.6watts LED
Env. Prot.	IP68
Conformity	BS EN 60958 CE UL Listed
Average Life	50,000hrs

The Lumisphere® Carnival range of LEDs is a fully Dimmable AC/DC LED plug in light module which uses 4 x 5mm high brightness light emitting diodes mounted onto a conformal coated heavy duty PCB, with plug in connector ensuring a highly visible wide angle light source with low power consumption. The units are designed to operate at low temperature and drive currents to achieve maximum performance.

Standard Colours:- Warm White, Cool White, Red, Blue, Amber, Green

Premium Colours:- Lemon Twist, Ice Blue, Pink Haze, Rose, Purple Mist and Cool Lime, Champagne and Crystal Ice.

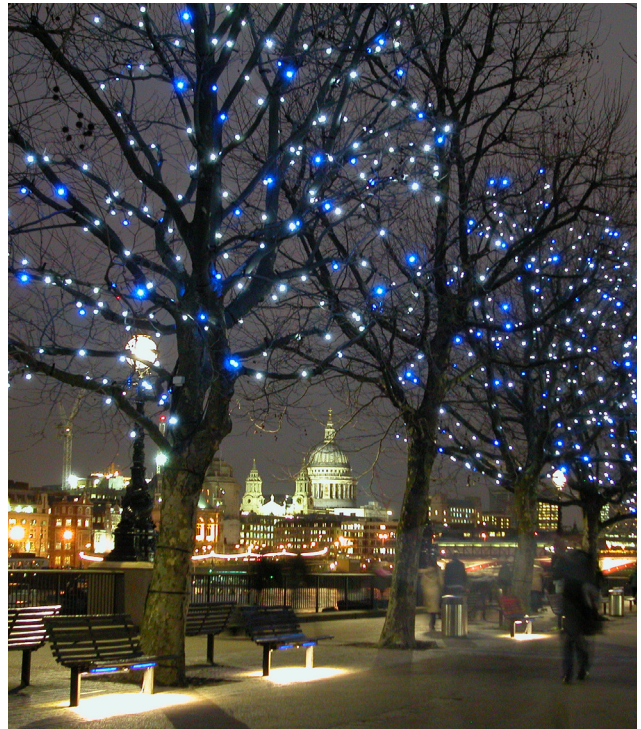

*Our festoons are ideal for tree lighting installations and can be seen in their full glory on London's Southbank*

## Large Harness Eco LED



### Specifications

Supply	12V DC SELV
Dimmable	on DC only
Light Source	0.2watts LED
Env. Prot.	IP68
Conformity	BS EN 60958 CE UL Listed
Average Life	50,000hr

The Lumisphere® ECO LED is a plug in LED light module which uses 2 x 5mm high brightness light emitting diodes mounted on a gold plated heavy duty PCB with plug in connector, ensuring a highly visible wide angle light source with low power consumption. The units are designed to operate at low temperature and drive currents to achieve maximum performance.

Colours:- Warm White, Cool White, Red, Blue, Amber, Green



*Lumisphere's large harness festoons are pressure watertight and IP68 rated, making them ideal for use in adverse conditions*

# LUMISPHERE® Active Festoon Systems

## RGBW (DMX) Colour Changing

### ADVANTAGES

The Lumisphere Active® System utilises data over voltage technology to provide a DMX controllable RGBW system that can be used in our existing X12 large harness festoon system.

The Lumisphere Active® RGBW Unit is a plug in LED module which uses 3 RGBW SMD LEDs consuming 1.0watts giving a bright and vibrant feel. The system can have up to 4 channels of independent control, and requires a Lumisphere Encoder to interface between controller and festoon. For further information on the Encoder, please see below.



### Specifications

Supply	24V DC
Light source	Lumisphere RGBW unit (3 chip)
Env. Prot	IP68
Conformity	BS EN 60958 CE Lampholder/Cable UL Listed
Average Life	50,000hrs



### Encoder (DMX input)



### Specifications

Supply	30V DC
Output	24V DC
Env. Prot	IP66
Control	DMX Input

### ADVANTAGES

The Lumisphere® Encoder acts as an interface between the DMX controller and the RGBW festoon system. The Encoder is enclosed within an IP66 rated box making it ideal for outdoor applications. Each encoder can drive up to 100 RGBW units and can be linked together to increase the number of units.



# LUMISPHERE® Active Festoon Systems

Example system layout can be seen in the below diagram:

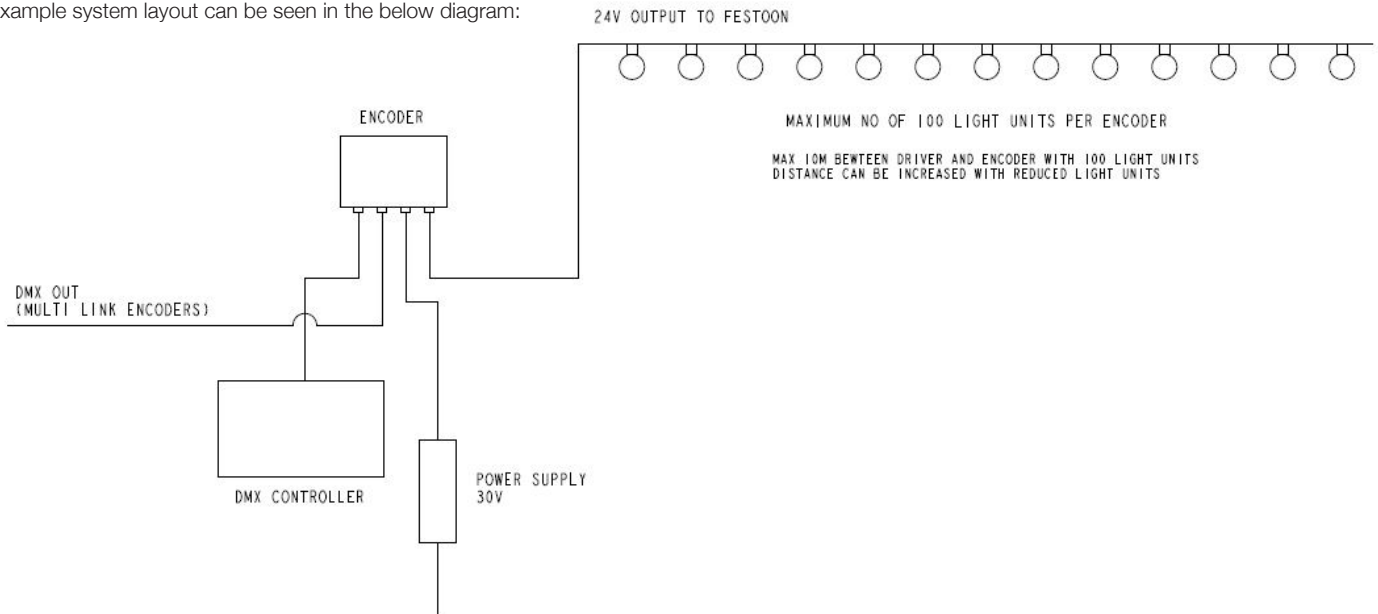

Lumisphere Active® RGBW systems look best with Clear, Frosted or White G or A type globes (White globes only available in G type).

The images below show the system in action in the Clear G Type Globes. For more information on the Lumisphere Active systems, please contact our Sales Team to discuss your project.

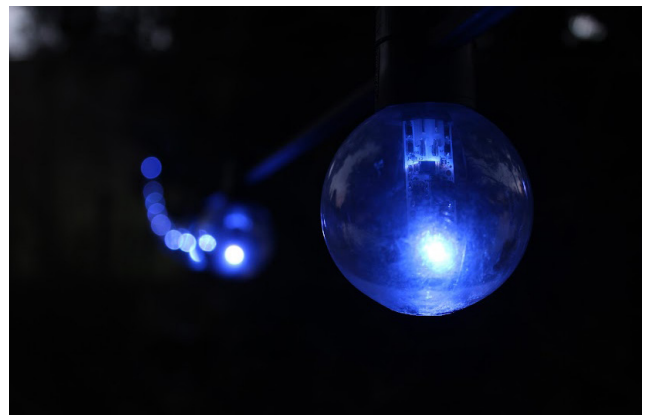

# LUMISPHERE® Large Harness X24

## Xenon X24



### Specifications

Supply	24VAC SELV
Lamps	24volt rigid loop Xenon lamps available 5, 8.5 and 10watts
Average Lamp life	20,000hrs @ the design voltage
IP rating	IP68
Globes	G type or A type
Conformity	BS EN 60958 CE, UL Listed

The Lumisphere® X24 Low Voltage System incorporates 24 volt Xenon Gas Filled Lamps of wattages of 5, 8.5 and 10w. These lamps have a life expectancy of approximately 20,000 hours at the appropriate circuit design voltage and are also extremely efficient with a colour temperature of 2700K. The X24 system is particularly suitable for permanent installation on buildings and structures where access for lamp changing is difficult. The lamps are multi position burning and resistant to vibration.



*Lumisphere X24 system used on the façade at Harrods, London*



*Lumisphere X24 system used on the Albert Bridge, London*

## Flasher Modules



### Specifications

<b>LFM Xenon Version</b>	
Supply	12 or 24V/AC nominal SELV
Lamps	12V 5watt Xenon 24V 5watt Xenon
Flashing rates	0.5 1.0 1.5sec
<b>LFM Orbical 8 LED version</b>	
Supply	12V AC/DC SELV
Light Source	1.0 watt LED
Env Prot	IP68
STD Flashing Rate	0.5 1.0 1.5sec

## X24 Retrofit LED Replacement

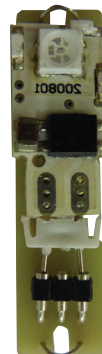

### Specifications

Supply	24v AC SELV
Light Source	Orbical/8 1watts Retrofit for Xenon
system	
Env. Prot.	IP68
Conformity	BS EN 60958 CE UL Listed

Lumisphere® Flasher Modules are designed to create movement within a static Lumisphere festoon. LFM can be retro fitted into existing X12, X24 and LED Lumisphere® systems. Any number of existing lamps or LEDs can be replaced with LFM which are manufactured to bespoke flash rates. Complete strings of festoons with LFM fitted can create random flashing effects.

Lumisphere® Retrofit modules are designed to be a simple replacement LED module for clients with the existing X24 festoon system. The conversion to LED does not require any replacements of existing transformers.

# LUMISPHERE® Large Harness Maintenance

## MAINTENANCE

Lumisphere's large harness systems comprise of 3 elements, each of which can be replaced individually back to the cable.



## LAMP HOLDERS

For Lampholder replacement, please contact us for guidance, and instructions can be issued.

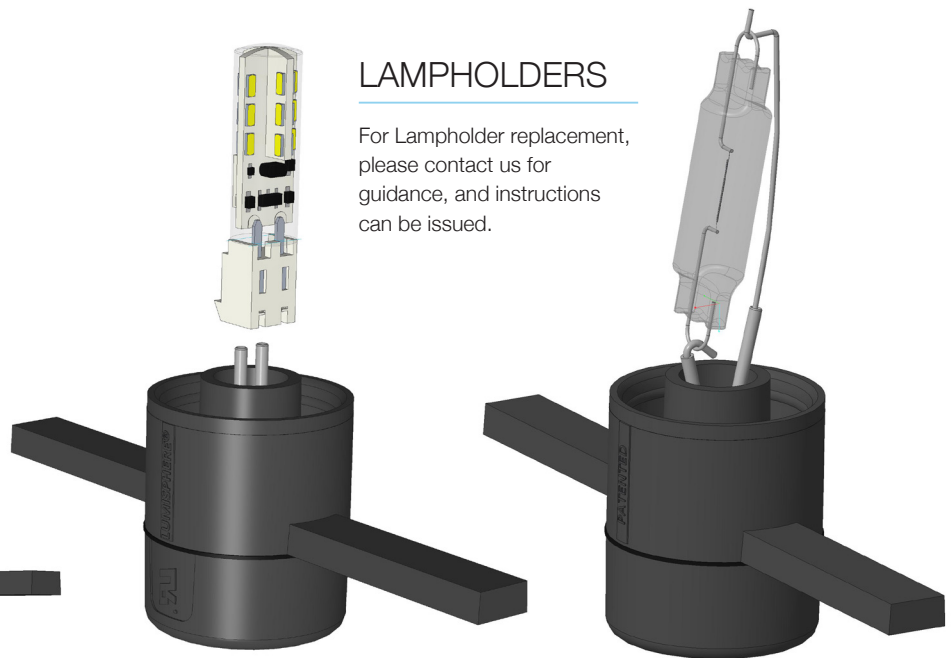

## GLOBES

The Globe can easily be replaced by pulling the Globe off the Lampholder and then pushing the new Globe back on, with the 'O-rings' providing the weatherproof seal.

## LEDS

If the LED should fail it can be simply replaced by removing the Globe, as above, and then pulling the LED off the Lampholder pins. The new LED can then be slid back onto the pins. (Note: Our Eco LEDs are polarity sensitive.)

## XENON LAMPS

When our large harness system uses a Xenon Lamp (X24) instead of an LED, the Lampholder contact pins have a different design. The Xenon lamp is 'unhooked' from the pins to replace and is reinserted in the same manner.

## SELF-ASSEMBLY

Lumisphere's Large and Small Harness festoon systems can be purchased in component form, if required, for self-assembly. In instances where irregular distances between light units are required, or on-site assembly of materials is required, e.g. signage, ceilings, fascias etc, this may be preferable. On-site self-assembly tools can also be purchased – please ask the team for more details.

# LUMISPHERE® Small Harness Festoon Systems

## ECO LED Systems



### ADVANTAGES

The Lumisphere® Small harness ECO LED System is designed for where a smaller more discrete harness is required, ideal for the illumination of young to medium size trees and building profiles. They are high quality fully weatherproof systems (IP68) comprising a flat twin HPN insulated cable with moulded light units attached at specified centres, providing a flexible lighting for a variety of decorative purposes. The Systems are particularly un-obtrusive when not in use.

### LUMISPHERE POWER SOURCES

There is an extensive range of Lumisphere® weatherproof LED driver units to provide a correctly matched power source to match the number of lights ensuring exceptionally long lamp life.

### APPLICATIONS

Coastal Promenade, Medium to Young Trees, Street and Building Decorations, Signs, Theme Parks, Pub and Restaurant Gardens, Swimming Pool Areas etc



#### Specifications

Supply	12VDC SELV
Dimmable	on DC only
Light source	Twin chip LED
Env. Prot	-0.2watts IP68



#### GLOBE OPTION

Round 45mm diameter, clear polycarbonate covers available for all small harness Systems.

### Electrical, Safety & Flammability Specifications

Lampholder:	Black UV stabilised Nylon 66
Lamp cover:	Dome shape UV Stabilised polycarbonate moulding, screw fit with a silicone rubber gasket. Colours available, Clear, Red, Blue, Green and Amber.
Cable:	Flat twin Black UV stabilised UL Style name: HPN UL File No. E94325 Heat resistance: 105 deg. C Voltage
Rating:	600V Insulating material: NEOPRENE HYPALON with 1.25mm <sup>2</sup> copper stranded conductors
Conformity:	Lumisphere® small harness system has been tested by BSI and found to comply with the relevant sections of BS EN 60598-2-2 1992 BS EN 60598-1 1003 for the classification IP68 dust/watertight – protected against submersion.

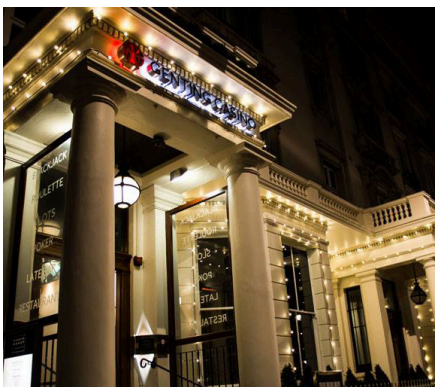

These units are designed to operate at low temperature and drive currents to ensure maximum performance characteristics with a calculated average 50,000 hour life subject to correct operating conditions.

The ECO LED light modules have been specially designed to plug into any Lumisphere small harness lampholders which are protected by a screw on polycarbonate clear cover to IP68.

The Lumisphere ECO LED system is designed to provide a cost effective, highly efficient LED lighting system for decorative lighting applications. The quality of the light and saturation of available colour makes the product ideally suited to trees, high profile buildings and structures. Particularly suited to use in applications where low running costs, low maintenance levels and reduced electrical loads are required.

# LUMISPHERE® Mini Light Systems



## MINI LIGHTS

The Lumisphere® Mini Light system is a high quality weatherproof system comprising of a flat twin insulated cable on which a number of small moulded light units are attached at predetermined centres.

## LUMISPHERE POWER SOURCES

The extensive range of Lumisphere® weatherproof transformers and drivers enable the power to be correctly matched to the number of lights ensuring a long-life span.

## APPLICATIONS

There are many applications where it is desirable to have high numbers of miniature low output lights, such as the illumination of boughs and branches of deciduous trees in winter when no heavy foliage is present, highlighting the individual shape and formation of the tree.

Other applications include structures and features which have complex designs and shapes such as motifs, signs, architectural focal points etc. where profiles are easily followed by the flexibility of closely spaced lights.

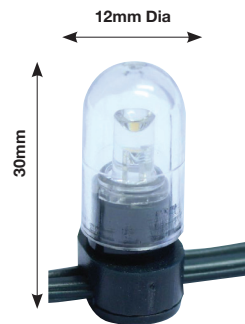

### Specifications

Supply	12v DC SELV
Light Source	Sub miniature 0.2w LEDs
Average Lamp Life	Life expectancy 50,000hrs
Env. Prot.	IP65 rated
Lampholder	Black moulded.
Cable	Flat twin core copper conductors. Dark green insulated sheath.
Lamp cover	Hemispherical polycarbonate clear cover.



## Ordering Information

### Standard Set

22.5m length of mini light system complete with 150 No Lights @ 150mm centres. 5m lead to first light. Total wattage = 30w  
Warm White or Cool White LEDs are standard, however different coloured LEDs are available, including an RGB version.

Lumisphere® Mini light festoons can be supplied in varying lengths and lights spaced at different centres. Lead time may vary. For further details contact our sales team.



# LUMISPHERE® Lighting Both Sides of The River Thames

Lumisphere® Festoon Lighting, can be seen throughout some of London's most iconic areas and structures

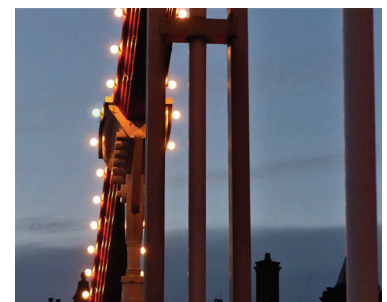
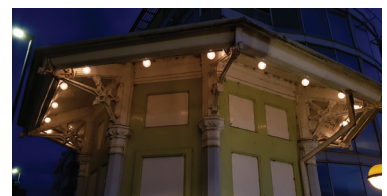

# LUMISPHERE® Lighting the World's Oceans

Lumisphere's dressing lights shining bright onboard some of the world's largest cruise liners

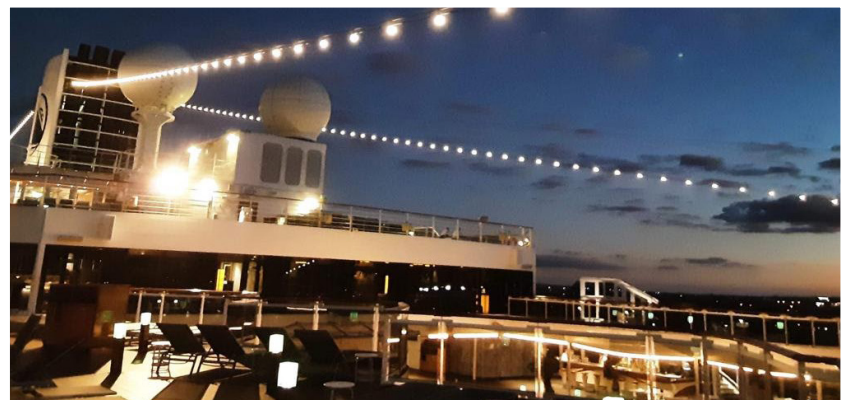
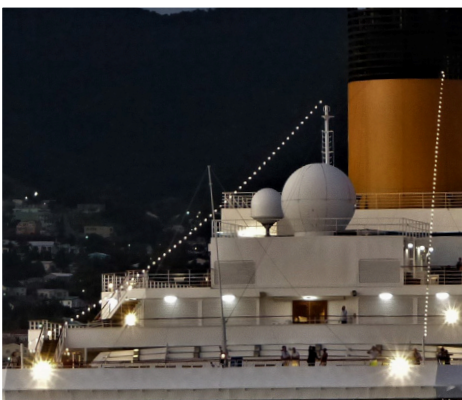

# LUMISPHERE® Lanterns

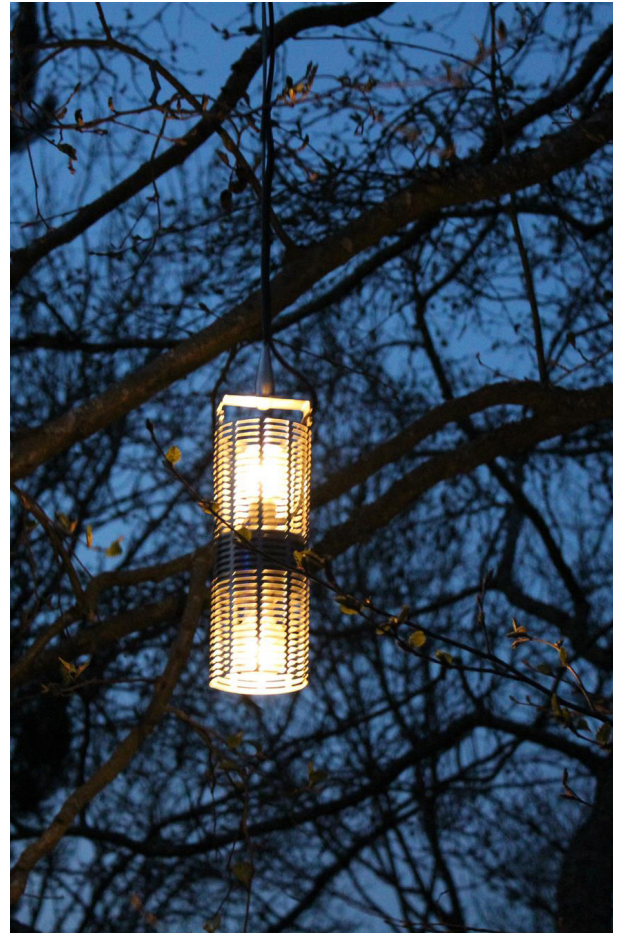

## Lumisphere® Lanterns

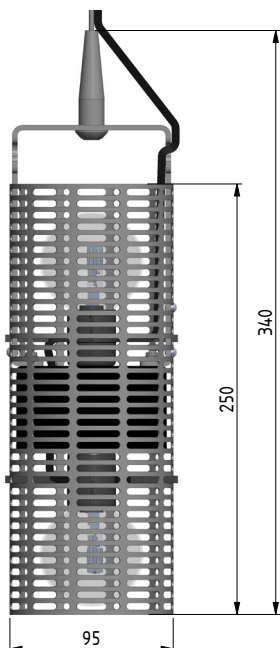

Lumisphere® Lanterns utilise two of our low voltage LEDs/lamps, enclosed in a Stainless-Steel mesh and suspended from a marine grade wire.

These are a great option for industrial themed interiors eg: bars, restaurants, retail displays etc.

Our Lanterns are made to order with a choice of Globe and LED colours available.

Contact us if you have a lighting idea we can help bring to life with Lumisphere products!

### Specification/features

- Light source – Any of our large harness LEDs/lamps can be used
- Environment Protection IP68
- Can be Dimmable if Carnival LED chosen
- Made to order
- Globe Colour and LED colour can be specified



# LUMISPHERE® Pendant Festoon

Lumisphere® patented systems, can be incorporated into bespoke designs to create unique durable lighting solutions



## Lumisphere® Pendant Festoon



Pendant lighting is a popular choice for many settings including restaurants, bars, outside seating and entertainment areas, as well as for a different look for tree lighting.

Lumisphere's patented lighting system has been incorporated into these attractive but robust Pendant festoons.

Our Pendants can be customised to your requirements, with drop length and loom length made to order. In addition, there are many colour options and combinations to choose from to create your bespoke product.

### Specification/features

- Light source – Any of our large harness LEDs/lamps can be used
- Environment Protection IP68
- Can be Dimmable if Carnival LED chosen
- Made to order
- A or G Type Globe available
- Globe Colour and LED colour can be specified
- Lampholder colour can be specified at additional cost

# LUMISPHERE® Low Voltage Safety Isolating Lighting Transformers



## Specifications

<b>Voltage</b>	<p>Input voltage 230-250v, 50/60hz</p> <p>Output voltage:</p> <p>12v Nominal for WP12 range</p> <p>24v Nominal for WP24 range</p> <p>10% under or overvoltage may appear in the supply, and the rated output of the transformer shall be selected accordingly – see chart.</p>	<b>Terminal Box</b>	<p>Mains voltage protection – Replaceable 20mm x 5mm cartridge fuse to IEC 60127-2 – 250VAC-300VDC. See transformer chart on page 17 for correct rating.</p> <p>Standard 90mm x 90mm terminal box rated at IP55, can be upgraded to IP66. Entry Gland 6-12mm diameter cables or multiple Lumisphere cables. Input and output terminal separated by insulating divider.</p> <p>Mains fused connector terminal block with wire protectors and replaceable fuse carrier.</p> <p>Low voltage output terminals 6mm x 25mm brass studs with copper clamping washer. See drawing on page 17.</p>
<b>Case</b>	<p>Manufactured from polyimide PA6 glass filled Nylon, complete with marine grade 316 stainless steel brackets. Post clamps available for column mounting.</p>	<b>Environmental Working Conditions</b>	<p>Lumisphere® transformers are suitable for use in adverse environmental conditions, i.e. damp, saline, or dusty conditions and can be mounted in exposed positions where severe weather conditions may occur.</p>
<b>Winding</b>	<p>High quality toroid winding is fully encapsulated in self-extinguishing grade rigid urethane resin with high electrical and mechanical properties and good resistance to thermal and mechanical shock. Insulation class B 130°C</p>	<b>Temperature</b>	<p>Ambient temperature range -25°C to 40°C with free air circulation around the transformer.</p> <p>Maximum temperature rise 50°C – maximum case temperature 90°C.</p>
<b>Protection</b>	<p>Isolation class 2, double insulated</p> <p>Low voltage protection – self resetting thermal cut out (120°C) incorporated into winding</p>		

## LIGHTING TRANSFORMERS

The Lumisphere® range of patented weatherproof low voltage lighting transformers have been designed especially for use with the Lumisphere® festoon system. The high quality of construction and combination of many unique features make it an ideal choice for most low voltage single or multi-light applications, especially for use in adverse environmental conditions.

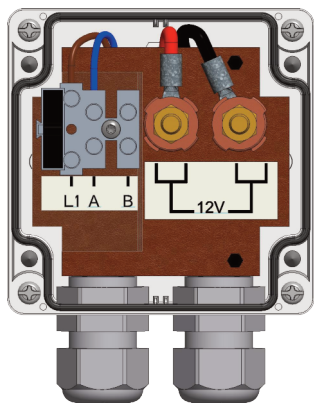

STANDARD TERMINAL ENCLOSURE 80VA TO 750VA

## SPECIAL FEATURES

- Fully weatherproof compact design suitable for exposed exterior mounting complete with wall mounting bracket.
- Integral terminal box conforming to IP55 or IP66 with special cable glands to accept cables 6mm - 12mm diameter.
- Double Protection with self-resetting thermal fuse incorporated in windings and replaceable anti-surge fuse housed in terminal block.
- Alternative mains connections are provided to regulate output voltage.
- Optional stainless-steel post clamp bands available for column mounting.

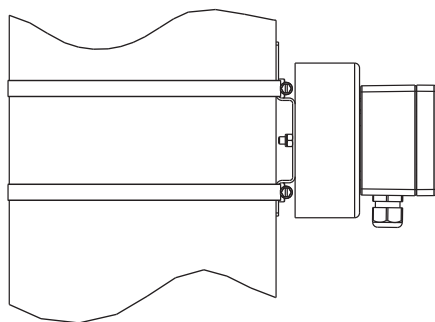

POST MOUNTED (SPECIFY STRAIGHT BRACKET & STAINLESS STEEL BAND CLAMPS)

### TRANSFORMER MOUNTING

80-350VA TRANSFORMERS FITTED AS STANDARD WITH STRAIGHT BRACKET FOR WALL OR POST MOUNTING.

425-750VA TRANSFORMERS FITTED AS STANDARD WITH 'T' BRACKETS FOR WALLMOUNTING ONLY. WHEN POST MOUNTING PLEASE SPECIFY STRAIGHT BRACKET

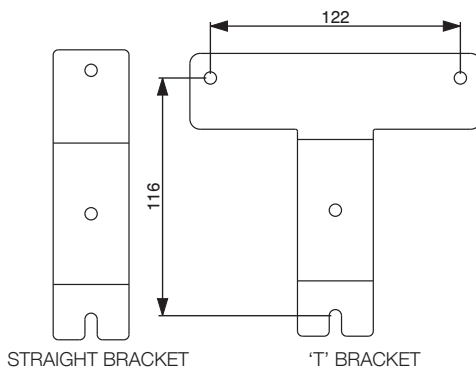

# TRANSFORMER DIMENSIONS AND MOUNTINGS OPTIONS

## STANDARD WP12 & WP24 TRANSFORMERS

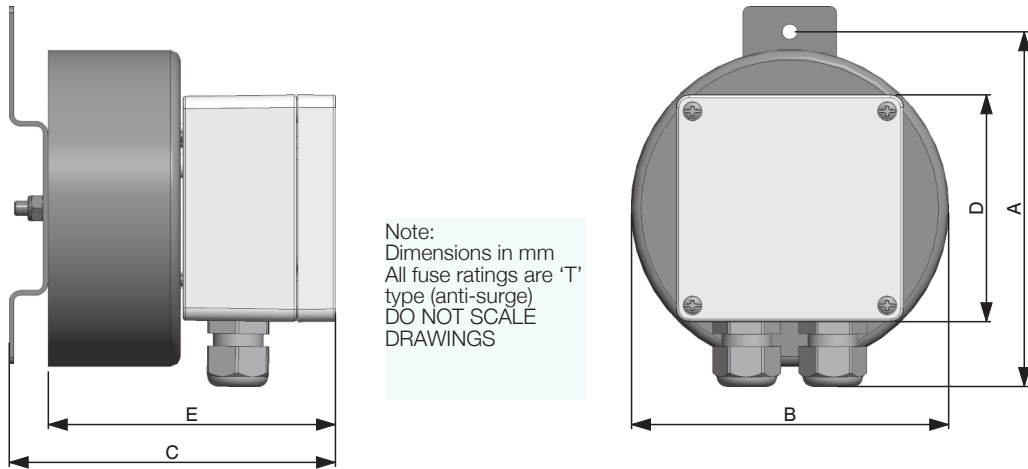

12V/24 RANGE (IP55 or IP66)							
VA	Dimensions					Fuse	Weight
	A	B	C	D	E		
80	150	125	130	90	52	1.0A	2.1
120	150	125	130	90	52	1.6A	2.5
160	150	125	130	90	52	1.6A	2.6
200	150	125	145	90	65	2.5A	3.4
250	150	125	145	90	65	2.5A	3.4
300	150	125	145	90	65	3.1A	3.9
350	150	125	145	90	65	5.0A	4
425	135	143	135	90	65	6.3A	5.6
500	150	150	145	90	80	6.3A	6.5
600	150	150	145	90	80	8.0A	6.5
750	150	150	160	90	80	10.0A	7.2

### 'On Load' Output Voltage Table

Example - Transformer 120VA. Load 110W. Mains 240V Load is 10W under the rated load. - Go to Minus - 10W column. Read across to 240V Primary Voltage. Output Voltage will be shown i.e. 12.4V using 'A' tapping, 11.9V using 'B' tapping.

WP12 RANGE										WP24 RANGE							
Actual Load Vs. Rated Load	Rated Load Minus -20W		Rated Load Minus -10W		at Rated Load		Rated Load Plus +10W		Rated Load Minus -20W	Rated Load Minus -10W		at Rated Load		Rated Load Plus +10W			
	230	12	11.5	11.9	11.4	11.8	11.3	11.7		11.2	23.2	22.2	23.1	22.1	23	22	22.9
Primary Voltage	240	12.5	12.0	12.4	11.9	12.3	11.8	12.2	11.7	24.2	23.2	24.1	23.1	24	23	23.9	22.9
	250	13.0	12.5	12.9	12.3	12.7	12.3	12.7	12.2	24.2	24.2	25.1	24.1	25	24	24.9	23.9
	Primary Tap	A	B	A	B	A	B	A	B	A	B	A	B	A	B	A	B

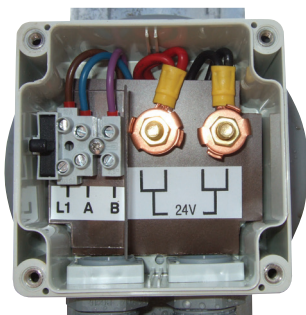

STANDARD TERMINAL ENCLOSURE (80VA TO 750VA inclusive)

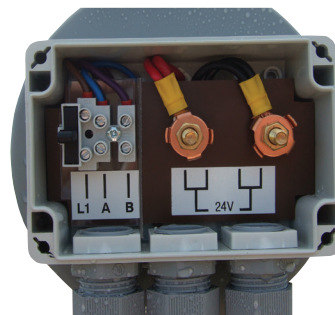

OPTIONAL 3 GLAND BOX (MF BOX) (500VA TO 750VA inclusive)

# LUMISPHERE® WP CV LED Driver Units

## LED DRIVER UNITS

The Lumisphere® range of weatherproof constant voltage driver units have been designed to complement the full range of Lumisphere® LED lighting systems. The constant voltage driver units have an IP55 rated enclosure (when mounted in the vertical position) and are suitable for column or wall mounting.

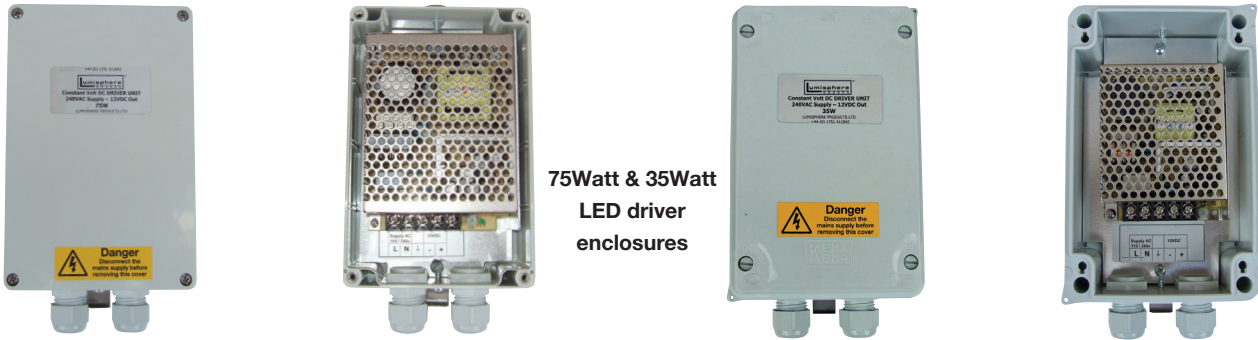

75Watt & 35Watt  
LED driver  
enclosures

### Specifications

<b>Input Voltage</b>	100-240volts	<b>Dimensions</b>	35 watt - L180mm x W120mm x D80mm 50 watt - L180mm x W120mm x D85mm 75 watt - L180mm x W120mm x D65mm 100watt - L202mm x W162mm x D82mm 150watt - L240mm x W160mm x D90mm
<b>Frequency</b>	50/60Hz	<b>CE conformity</b>	ICE 60950-1 : 2001
<b>Output Voltage</b>	12 volts DC	<b>Order ref</b>	WPLED35 for 35 watt driver WPLED50 for 50watt driver WPLED75 for 75watt driver WPLED100 for 100watt driver WPLED150 for 150watt driver
<b>Output Power</b>	35,50,75,100,150watt available		
<b>Protection</b>	Short circuit and overload protection		
<b>Environmental Working Conditions</b>	Saline or dusty conditions, can be mounted in exposed positions where severe weather conditions may occur		

## LUMISPHERE® Dimming Systems

Lumisphere Carnival and ECO LED systems are most suitable for dimming via any of the below options

- 1) 1-10volt electronic LED drivers 20watt,100watt and 180watt, which can be supplied fully enclosed in weatherproof enclosures or in skeleton form, complete with rotary dimmer.
- 2) Triac leading edge LED Electronic Drivers - 25watt, 40watt and 100watt electronic drivers for internal use, Dimmer supplied by others
- 3) PFC phase control dimmers (supplied by others) to dim our Lumisphere Toroidal Transformers
- 4) Dali Control using our Electronic 180 LED Drivers which can be supplied fully enclosed in weather proof enclosures or in skeleton form. Dali control by others.



# LUMISPHERE® Simultaneous Switching Unit (SSUs)

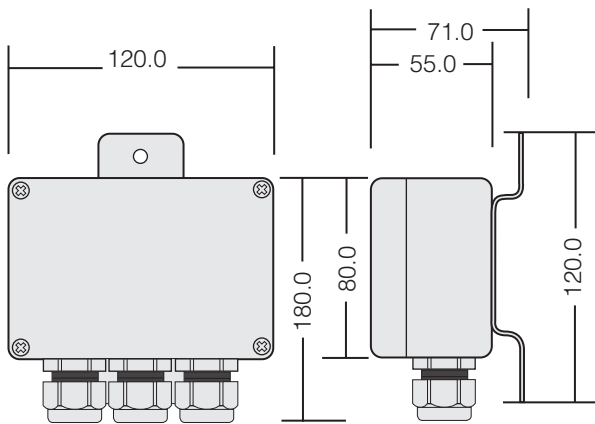

## Specifications

Supply	220/240V AC (50Hz)
Load	8A inductive max. (1900W)
Switch Sense	9 to 27V AC, 20mA load
Zero Switching	±34V max.
Ambient Temp.	40°C max.
Isolation	Maintains BS3535 (4kV) isolation. Switch line to mains supply.
Enclosure	Impact/temperature resistant polycarbonate
Environmental Protection	IP65
Mounting bracket	Column and wall

## SSU-8A SIMULTANEOUS SWITCH UNIT

The SSU-8A is a high quality, solid state switching device that can be used to control multiple loads simultaneously from one switching point. The device operates using the low voltage signal from the end of a lighting loom to switch the mains power to the next transformer in turn. The advanced electronic control utilises zero-volt switching techniques to minimise the surge load on mains feed at switch, maintaining complete isolation from the low voltage supply. The major advantage of using the SSU units in place of multiple time-clocks is that all interconnected circuits, irrespective of phase will be switched simultaneously from one time / photocell control, eliminating the need for multiple clock adjustments and manual synchronisation. The unit is housed in a tough, impact resistant polycarbonate enclosure with high quality cable glands and environmental protection to IP65, complete with post/wall mounting bracket for strap fixing to columns.

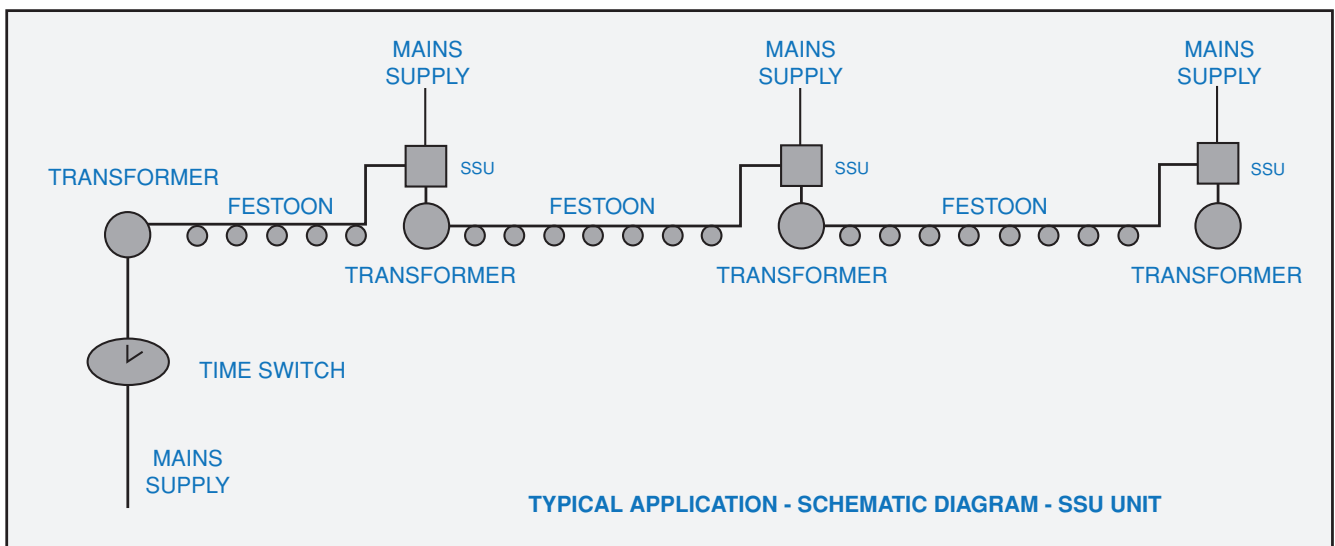
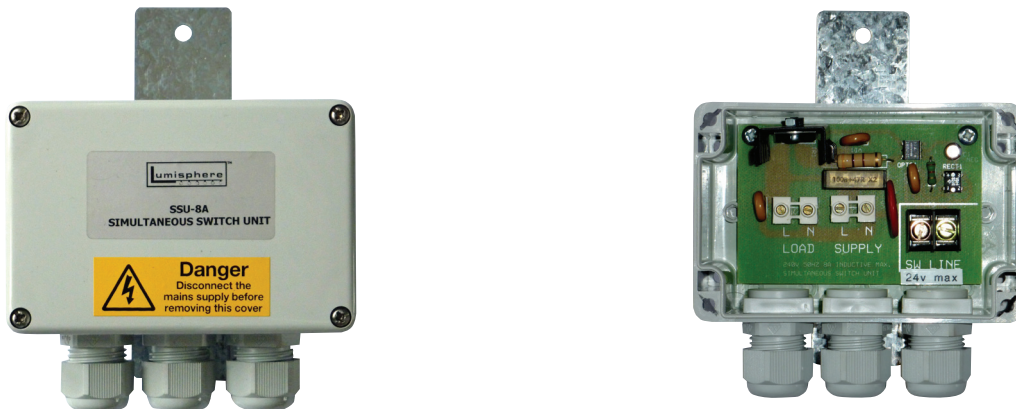

# LUMISPHERE® Selection and Installation Guide

Lumisphere® Low Voltage Lighting Systems operate at a nominal 12 volts (X12) and a nominal 24 volts (X24). Due to the characteristic of a low voltage system a voltage drop occurs in the system which creates some limitations on the number of lamps that can be used on one string. The variables that effect the system voltage are the - number of lights and rating - spacing of lights - transformer rating - mains voltage - and the choice of supply tapping on the transformer. These variables must be taken into account in circuit designs. The following general rules may be applied with regard to the number and spacing of lamps.

## X24 - 24V SYSTEM

Maximum number of lamps with 2 metres to first light

SPACING	5w	8.5w	10w
100cm	50	35	25
50cm	72	51	36
33cm	86	60	43
25cm	100	70	50

## LARGE HARNESS LED SYSTEMS

Maximum number of lamps with 2 metres to first light

SPACING	0.2w	0.6w	1w	2w
100cm	200	115	80	70
50cm	280	160	110	90
33cm	330	190	135	100
25cm	400	220	155	125

Note: Total load on cable fed from one end should not exceed 275 watts for the 12v system and 550 watts for the 24v system (23 Amperes max).

Select transformer required by multiplying lamp wattage by the number of lamps used ie. 100x5w lamps = 500VA transformer. For further information on the above, contact Lumisphere Products Ltd. Technical Department who can provide full circuit designs and advice for given projects.

## GENERAL NOTES ON INSTALLATION

Where it is required that the transformers and mains supply are to be some distance from the festoons ie. transformers located in pit adjacent to large Christmas tree, 6mm<sup>2</sup> csa. low voltage supply cables and distribution boxes are available.

The end of the Lumisphere® cable should be sealed with end cap EC1 and silicone rubber sealant.

The Lumisphere® system may also be used for illuminating trees and other structures. Methods of fixing will be dependant upon conditions and expected duration of installation. See straps & buckles section.

## LOOPS

The Lumisphere® system may be used as a freely suspended festoon between fixed points at not more than 5metre centres to form loops not exceeding 30cm in depth. If spans of greater distance are required a catenary wire should be used and the Lumisphere® cable firmly strapped to it either to form shallow loops not longer than 5 metres using strap and buckle fixing SB90, or strapped tightly to the straining wire at approximately 50cm centres using nylon tie NT100; see figures A, B below. Care should be taken to ensure chaffing does not occur.

It is recommended that the Lumisphere® cable be firmly attached to buildings and structures by means of backplate BP60 or cable clips or ties on either side of the lampholder at not more than 50cm spacings. For fixings to fascias and boards see diagrams figures C, D, E.

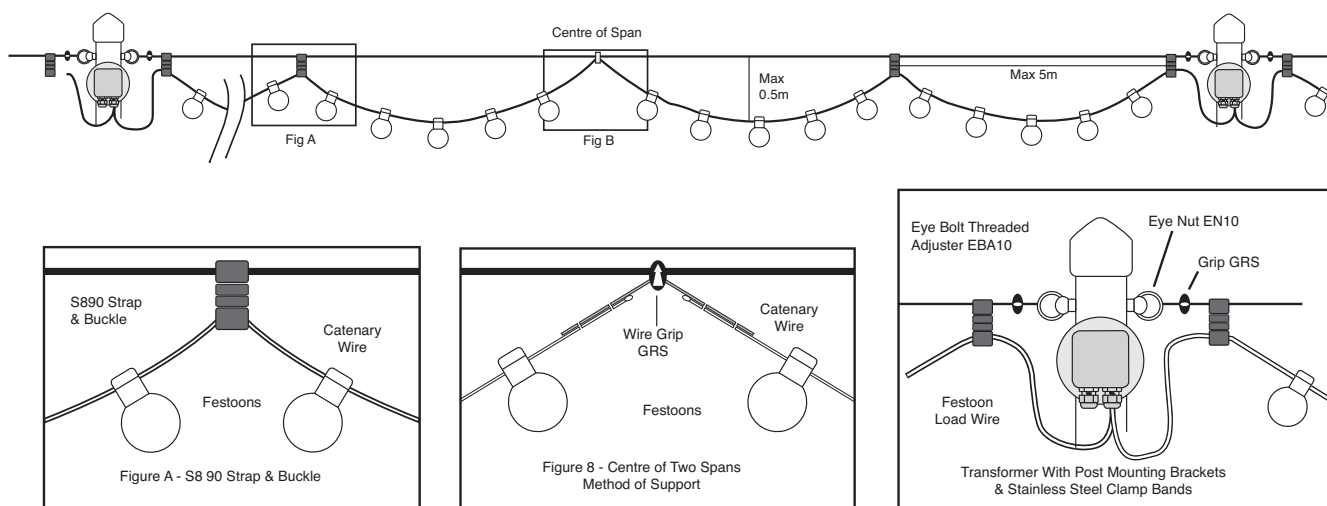

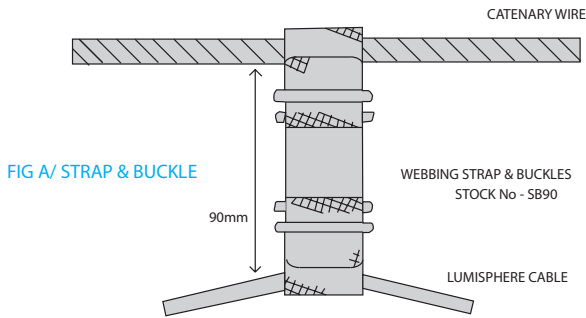

FIG A/ STRAP & BUCKLE

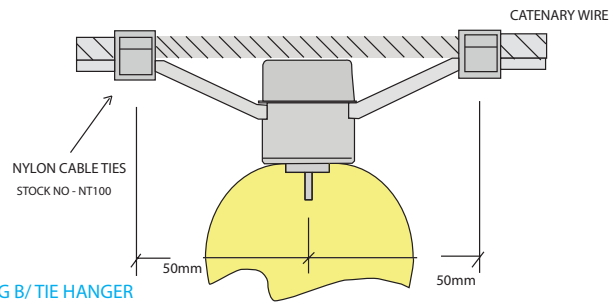

FIG B/ TIE HANGER

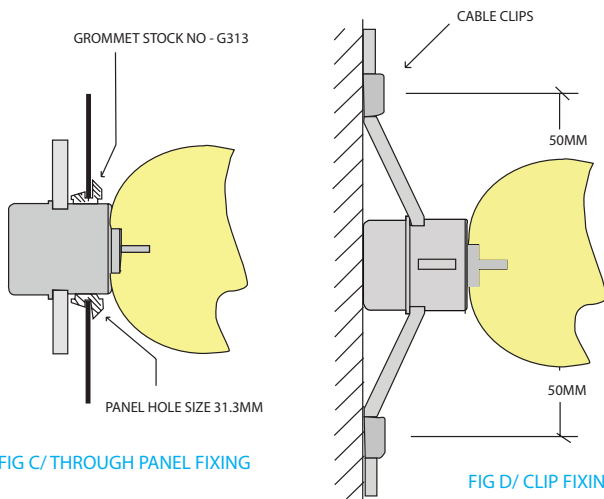

FIG C/ THROUGH PANEL FIXING

FIG D/ CLIP FIXING

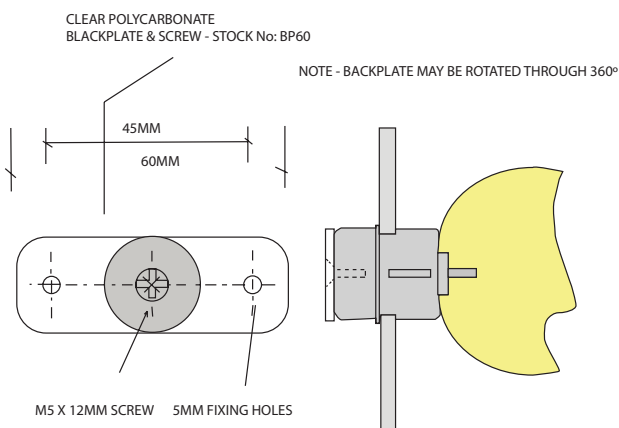

FIG E/ BACKPLATE FIXING



Snap on hangers

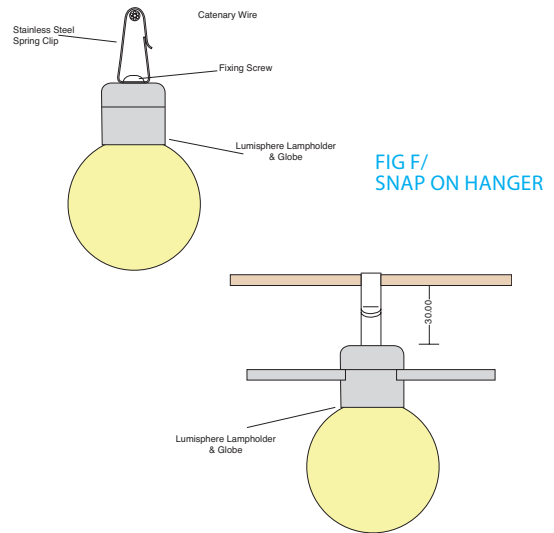

FIG F/ SNAP ON HANGER

## MOUNTING OPTIONS

**Figure A:** The strap type hanger is manufactured of nylon webbing and hard nylon buckles to provide a flexible mounting to a taut catenary wire where drapes are made with the festoon. It prevents damage to the festoon cable from abrasion and twisting. For use at a maximum of 5m centres. Stock No: SB 90

**Figure B:** The festoon may be attached to the catenary wire with nylon ties both sides of the lampholder where it is held tight against it. Where lamp spacing exceeds 0.5m additional fixings are required. Stock No: NT100

**Figure C:** The lamp holders may be mounted through a panel sign board or trunking using a special grommet/rubber bush to enclose the lampholder and cable. Stock No: G 313

**Figure D:** The festoon may be held tight against a flat surface such as a fascia using standard cable clips 50 mm either side of the lampholder.

**Figure E:** Backplate may be used to attach the lampholders to surfaces such as brick & board. The plate is manufactured in clear polycarbonate to reduce its visibility and is supplied complete with a nickel plated brass lampholder screw. Stock No: BP 60

**Figure F:** The Lumisphere Snap on Hangers are designed for installations where the lamp assembly is required to hang from a pre fixed wire rope installation. The Hanger is constructed from 1mm Marine Grade stainless Steel and comes in 3 options

**Standard Snap on Hanger:** for 6mm Wire Rope installations where the lamp assembly can be clipped onto the Wire Rope

**Premium Snap on Hanger:** For 10mm Wire Rope Installations

**Super Premium Snap on Hanger and Pinch Bolt:** – For 10mm Wire Rope Installations where a Draw wire is to be fitted.

In all installations the festoon lighting cable should be secured to the wire rope at either end of each section of lighting to prevent concertinaing of the festoon in any environmental conditions.

# General notes on installation continued

**TRUNKING SYSTEM**  
 TR3M - Punched Trunking 3m  
 RO28 - Retaining 'O' ring  
 (state Qty Required)

Hole Centres to be Specified

Optional Band Fixing Slots (4 / length)

Retaining 'O' ring 50.00 25.00

**MATERIAL - uPVC, UV Stabilised**  
**COLOUR - self colour white (may be painted)**  
**SURFACE OF LINEAR EXPANSION - 5.5x10per °C/2mm per 3m with 16°c rise**  
**ORDER CODE - TR3M/ [hole centres] add FS for optional fixing slots.**  
 (standard length - 3 metres)

**CATENARY WIRE & ACCESSORIES**

THREADED EYE BOLT ADJUSTER  
 180MM x M10 THREAD - EBA10

EYE NUT M10 THREAD - EN10

5mm CATENARY WIRE  
 WR - 5(100M rolls)

THIMBLE - TH5

WIRE GRIP - GR5

PRE-FIX - SS For Stainless Steel, G For Galvanised Steel on all parts

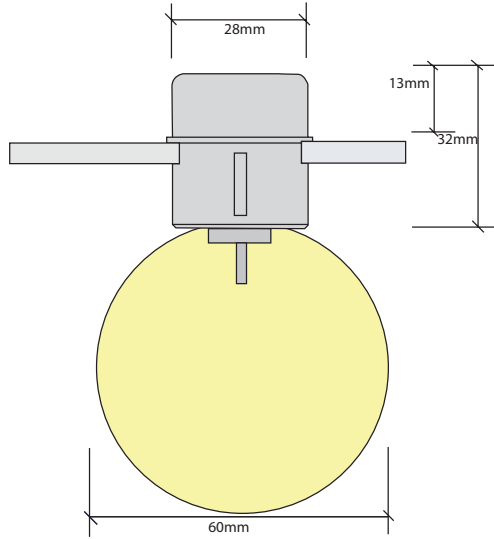

LIGHT ASSEMBLY DIMENSIONS

## GENERAL DIMENSIONS

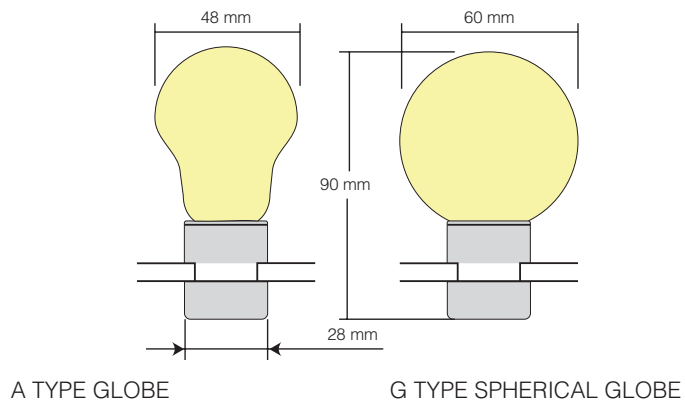



# LUMISPHERE® Fixing Accessories

## STRAPS & BUCKLES

SB Straps & Buckles are manufactured from 25mm nylon webbing with nylon 66 black buckles. When configured as per the image, they are adjustable for installations such as tree boughs and branches, and are expandable with tree growth.

The SB hangers are also most suitable for suspending festoons from tensioned catenary wire especially when loops are required in the festoons. The correct use of SB hangers will prevent fatigue in the festoon.

SB hangers are supplied in 4 standard sizes each with 4 nylon buckles.

The nylon strap can also be supplied in 50m rolls with 400 buckles for cutting on site.

- SB23** For wire or branch 5mm-20mm
- SB33** For wire or branch 20mm-30mm
- SB40** For wire or branch 30mm-70mm
- SB50** For wire or branch 60mm-100mm  
50m Roll webbing and 400 Buckles

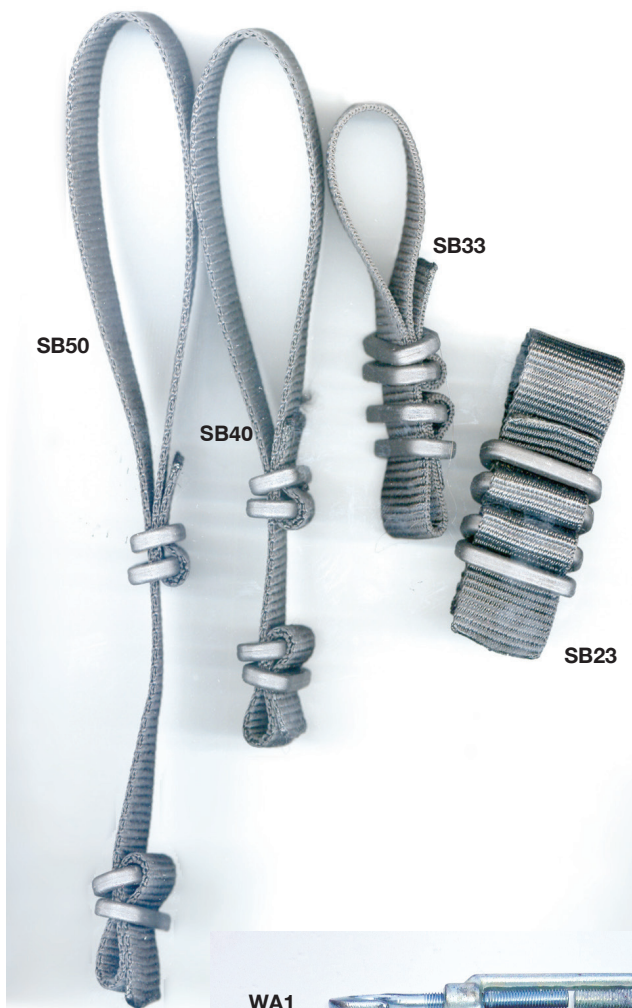

## CATENARY WIRE ACCESSORIES

Lumisphere® supply a range of catenary wire fixing accessories to support our products. Accessories are available either Marine grade Stainless Steel or Galvanised Steel.

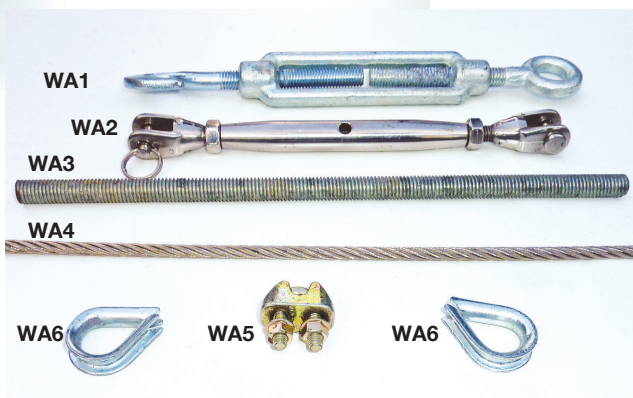

- WA1 Hook & Eye Tensioner
- WA2 Jaw Jaw Tensioner
- WA3 All Thread
- WA4 Wire Rope
- WA5 Wire Grip
- WA6 Thimble



## CABLE TIES

Cable Ties are available at various different lengths. Contact us to find out about our full range.

*See our website for more details of fixing options.*

# LUMISPHERE® Gallery

Lumisphere's festoon lighting can be seen along many coastlines, waterways and piers.



Lumisphere lights are also ideal for celebrations or permanent lighting installations in many entertainment, restaurant and retail displays.



# LUMISPHERE® Gallery

Lumisphere's versatile lighting systems are used in many spectacular architectural lighting projects worldwide.



We are proud to see our lights used in many festive lighting displays year after year with very little or no maintenance required.



EFFECTIVE  
LIGHTING  
SOLUTIONS

DESIGN AND  
TECHNICAL  
ASSISTANCE

EXCEPTIONAL  
AFTER CARE  
SERVICE



**SALES:**

Tel: **+44 (0)1245 329999**

Fax: **+44 (0)1245 322600**

Email: **sales@lumisphere.co.uk**

**HEAD OFFICE & TECHNICAL:**

Lumisphere Products Ltd

Red House

Rosedale Abbey

Pickering

North Yorkshire YO18 8SE

Tel: **+44 (0)1751 411942**

Fax: **+44 (0)1751 417616**

Email: **accounts@lumisphere.co.uk**

[www.lumisphere.co.uk](http://www.lumisphere.co.uk)

Lumisphere®  
Products Ltd  
lumisphere® [www.Lumisphere.co.uk](http://www.Lumisphere.co.uk)